

REV.	DATE	DESCRIPTION	ECN#	BY

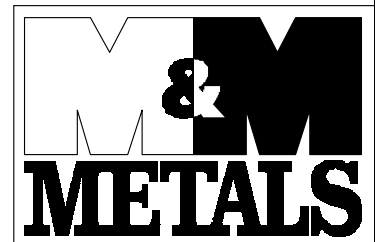
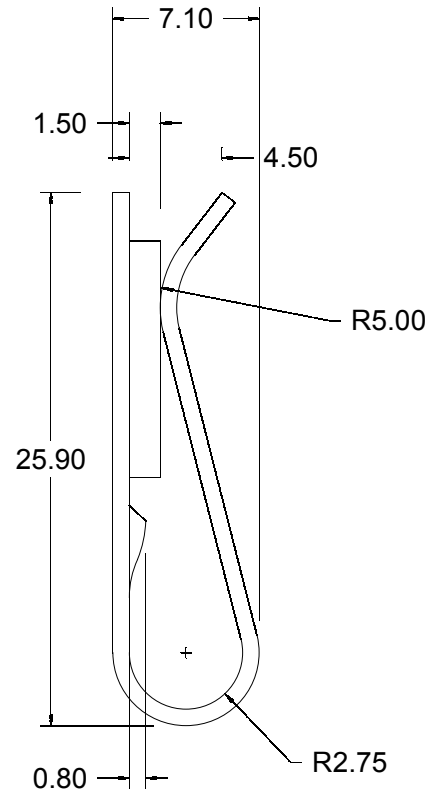
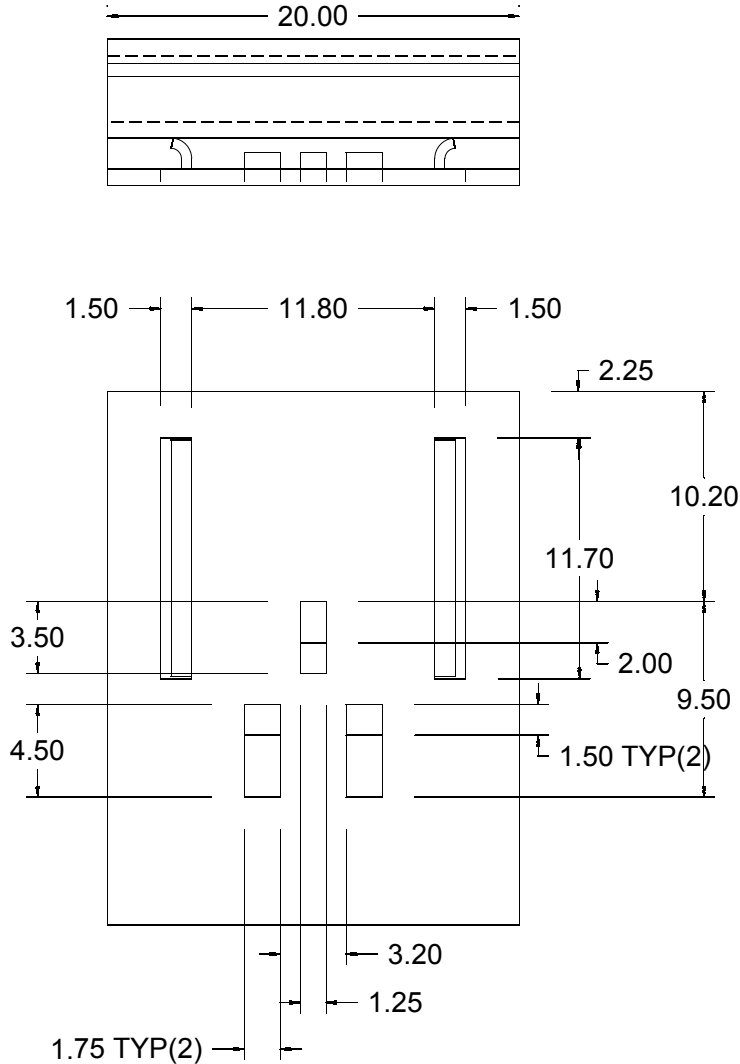

908 E. PIONEER DR.
 IRVING, TX 75061
 PHONE: 972-721-7174
 FAX: 972-438-1247
 e-mail: heatsink@mmmetals.com
 www.mmmetals.com

4	NOTICE OF PROPRIETARY INFORMATION THIS DOCUMENT IS THE PROPERTY OF M&M METALS AND SHALL NOT BE REPRODUCED OR COPIED, IN WHOLE OR IN PART, WITHOUT THE WRITTEN PERMISSION OF M&M METALS.
3	
2	
1	
NOTES (UNLESS OTHERWISE SPECIFIED)	

TOLERANCE (UNLESS OTHERWISE SPECIFIED)	
DIMENSIONS ARE METRIC	
$X \pm 0.5$ $XX \pm 0.25$	
FINISH: BLACK ANODIZE	MATERIAL: AL5052 T=0.8

DWG. BY: B.H.	DATE: 4/15/02
CHECKED BY:	DATE:
APPROVED BY:	DATE:
ECN#: 0221	DATE:

TITLE BLOCK DO NOT SCALE DRAWING	
MM5092B	
SIZE: A	DRAWING NUMBER: MM5092
REV.:	SHEET 1 OF 1