

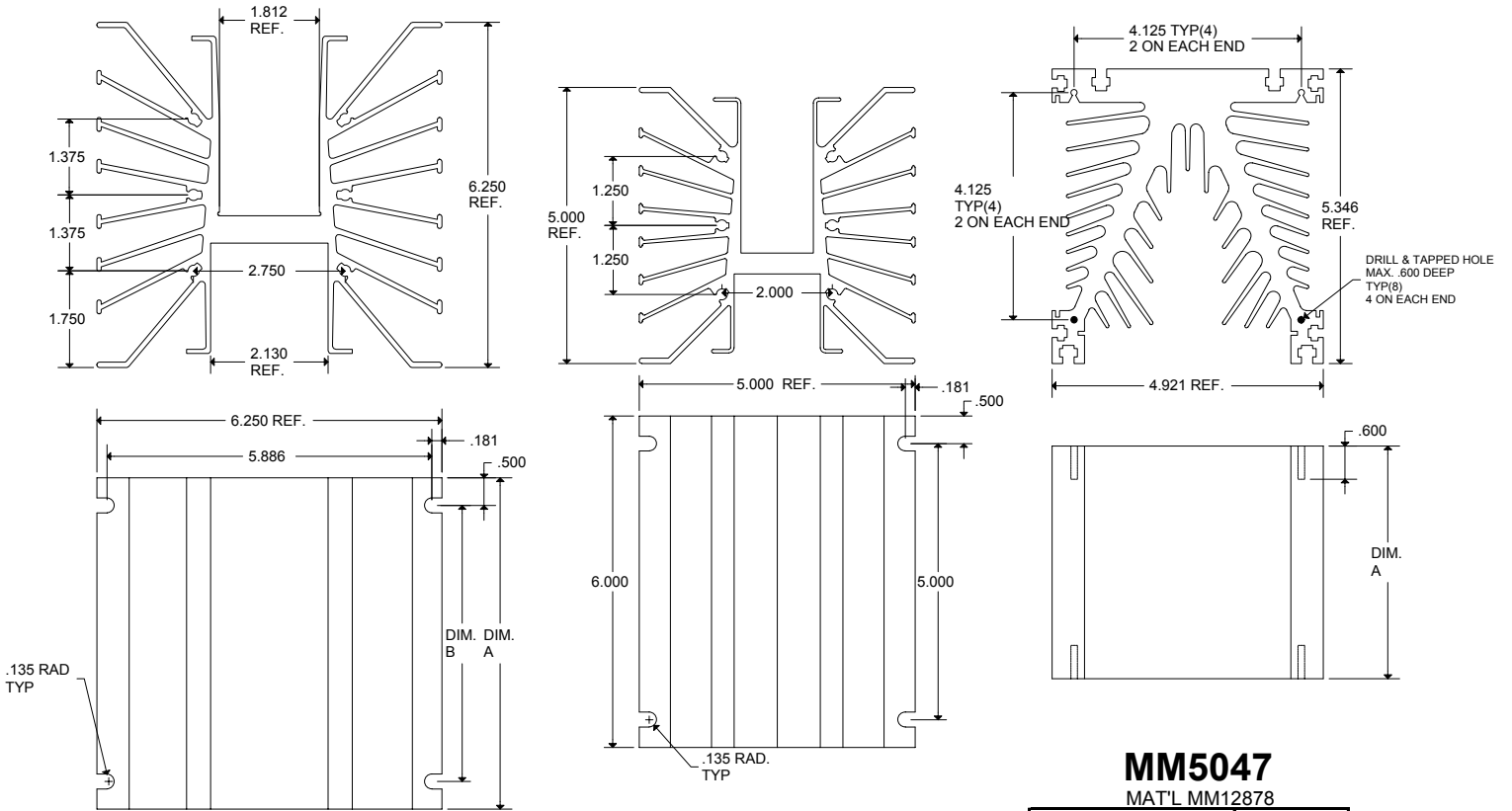

M&M Metals

EXTRUDED HIGH POWER HEATSINKS

- Extruded aluminum fin heat sinks for forced convection applications
- Standard mounting hole pattern



MM5061

MAT'L MM11759

PART NUMBER	DIM. A	DIM. B
MM5061-6	6.000	5.000
MM5061-9	9.000	8.000

MM5060

MAT'L MM13443

MM5047

MAT'L MM12878

PART NUMBER	DIM. A
MM5047	7.087
MM5047-001	4.725
MM5047-002	11.811

Contact M&M Metals for:
 -available finishes
 -standard hole patterns
 -standard hole pattern layouts

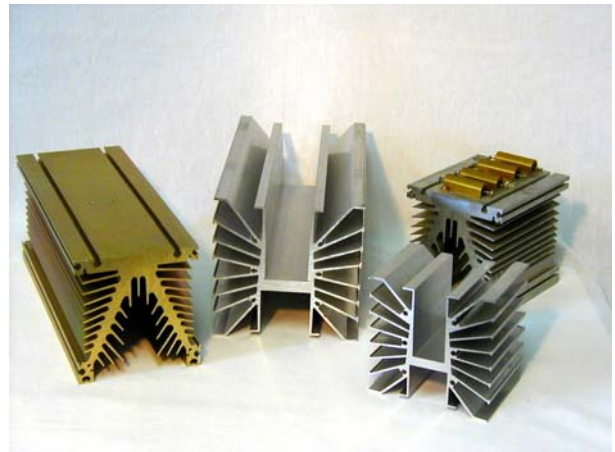

908 E. Pioneer Drive
 Irving, TX 75061
 Phone: 972-721-7174
 Fax: 972-438-1247
 E-mail: heatsink@mmmetals.com